

Specifications for the DB928-4839H Motorized Impeller

Submitted by McLean, A Pentair Company

DB928-4839H Motorized Impeller



The air mover described in this specification is the DB928-2439H. The unit is available a metal impeller blade. The unit uses an external motor driver. The following information includes performance characteristics, sound data, bearing life estimations and mechanical details.

General Specifications

Air Flow Performance	1070 CFM @ 0.0" wg. 0 CFM @ 2.69" wg
Voltage	48 VDC Nominal
Operating Ambient Temp.	-20 TO +65 °C.
Humidity	5 – 95 % Non Condensing
Agency Approval	UL, CUL, CSA, TUV

Air Flow Performance

Air Flow Performance of the DB928-4839H Motorized Impeller

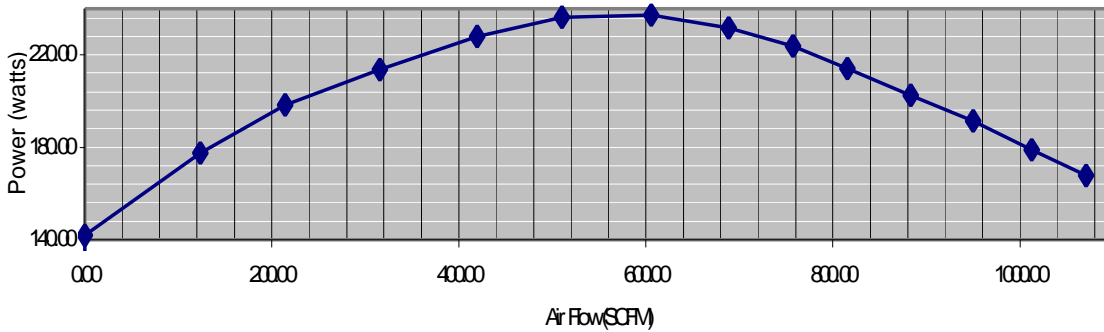
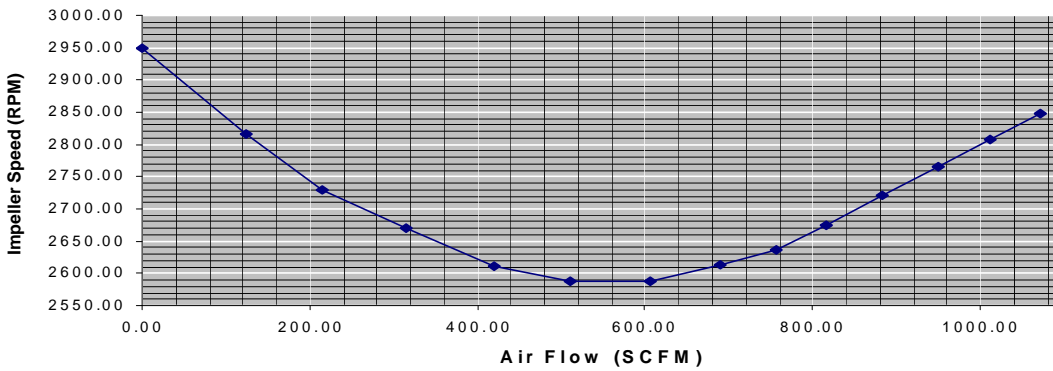
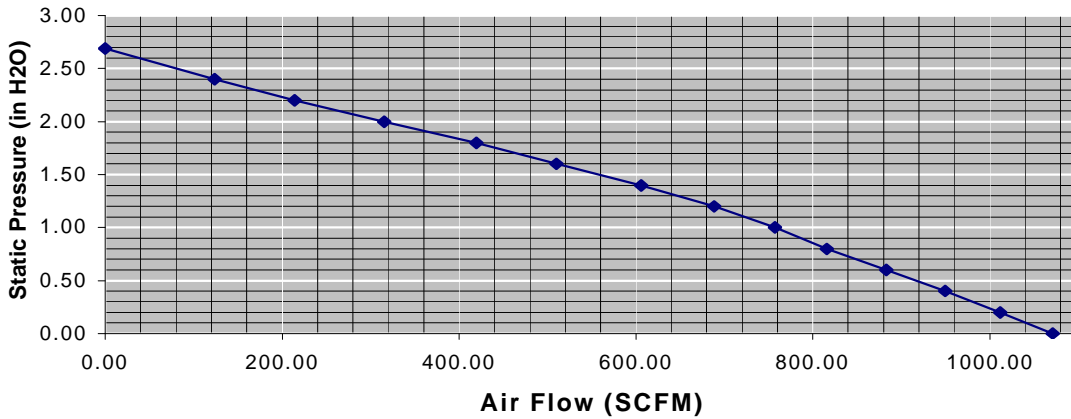

Electrical Performance

Power Specification

Nominal Voltage (VDC)	Voltage Range (VDC)	Max Operating Current (Amperes)	Inrush Current (Electronically Limited) (Amperes)	Nominal Power (Watts)
48	32-60	5.0	6.40	168.0

Alarms / Sensors Available

The following is a list of tachometer and alarm output signals available:

- 1) **Tachometer Signal**
 - a) 5 VDC two pulse/rev (Standard)
 - b) 12 VDC two Pulse/rev (Optional)
 - c) Open Collector Two Pulse/ Rev (optional)
- 2) **Alarm Signals**
 - a) Open collector
 - b) TTL Logic Level
 - c) Solid State Switch
 - d) Opto-Isolator

Open Collector - The alarm signal is generated from the collector of a bi-polar transistor and is referenced to the common return line. The customer provides the external pull-up resistor for producing the logic “High” state. It is recommended with this configuration that the alarm signal be pulled up high to indicate a failure. This will ensure that an alarm signal is generated if the air mover is not connected.

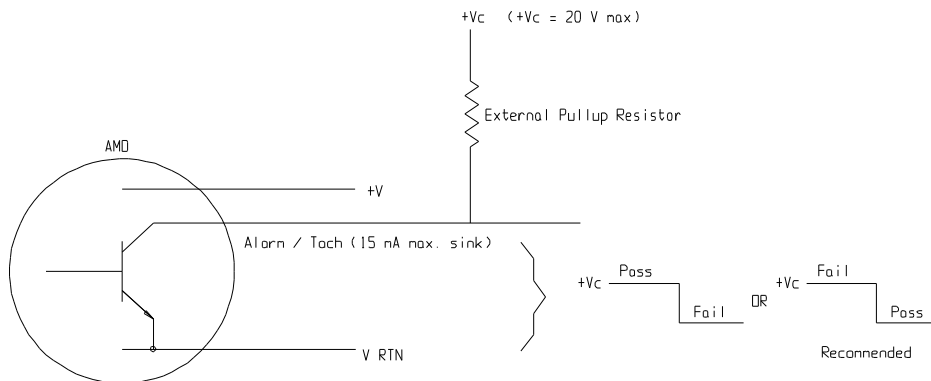

Transistor Logic - 5VDC TTL Logic or 12 VDC is available with either high or low signal on pass. The alarm signal is generated from the collector of a bi-polar transistor and is referenced to the common return line. An internal pull-up resistor to +5 or +12 VDC produces the logic "High" state.

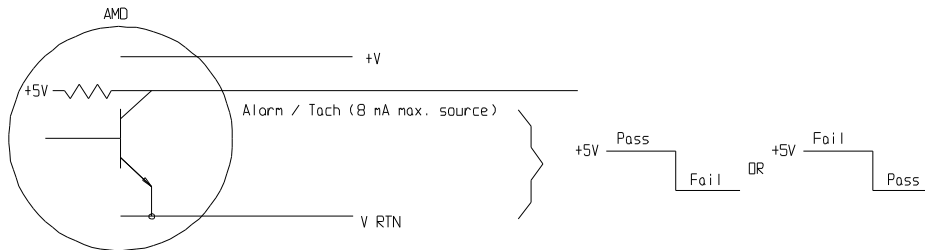
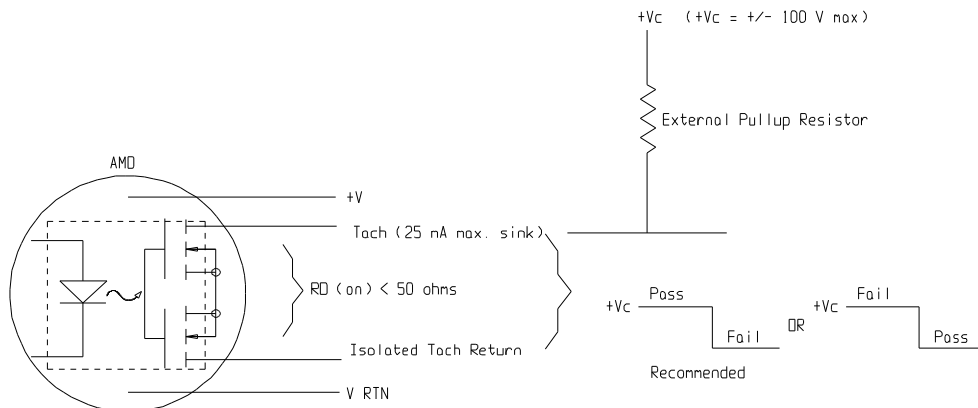
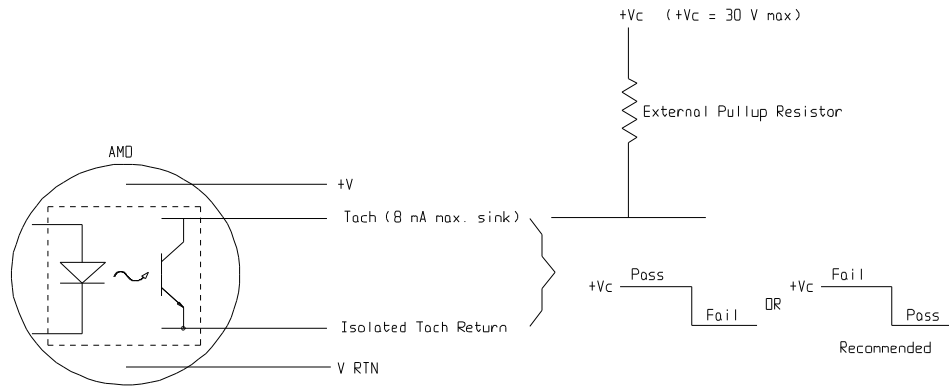

Photo MOS Output (Solid State Switch) – The alarm signal is generated by an optically isolated solid state relay. This signal is referenced to a separate isolated return line. The pull-up resistor must be provided externally by the customer. Voltages switched by the solid state switch may be either AC or DC. It is recommended with this configuration that the alarm signal be pulled up high to indicate a pass condition and go low on failure. This will ensure that an alarm signal is generated if the air mover is not connected.



Optically Isolated Alarm – The alarm signal is generated from collector of an optically isolated transistor and is referenced to an isolated return line. This isolated return line connects to the emitter of the opto-isolator. The customer provides the external pull-up resistor for producing the logic “High” state.



Speed Control

Two types of speed control are available as an option, pulse width modulation (PWM) and resistive input.

Resistive Input -- The speed is controlled by an external resistor that is placed across the return and control lead of the motor. An open condition of the external resistor causes the motor to run at maximum speed. A PTC thermistor can be added in place of a standard resistor so that the speed of the fan will be a function of ambient temperature. An open thermistor will simulate a high temperature and cause the motor to run at maximum speed.

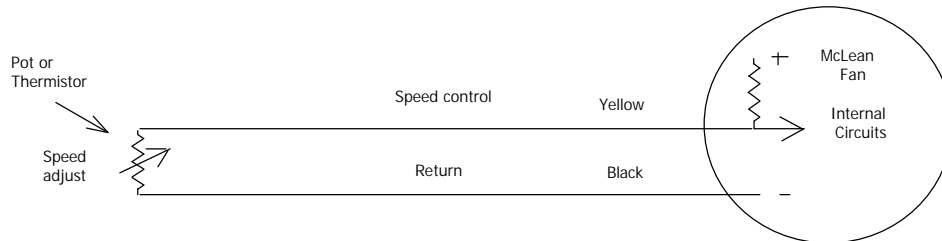

Pulse Width Modulation (PWM) – In this configuration, an open collector transistor supplied by the customer is placed across the return and control lead of the motor. The PWM frequency should be kept between 250Hz and 2kHz. When the duty cycle on the PWM wire reaches 100% (or circuit becomes open), the motor goes to maximum speed. A 0% duty cycle will shut the motor off. Duty cycles between 1% and 99% will allow speed control.

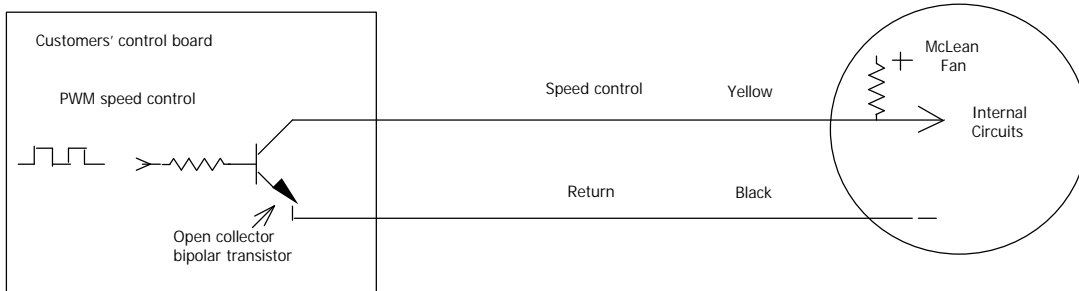

Acoustical Noise

The acoustical noise reading taken 1 meter from the center of the intake of the impeller is:

81 dBA @ 0.0" wg backpressure

Reliability

The following reliability calculations are made using actual bearing temperatures and loading. It is important to note that these calculations are based on a statistical model that evaluates both bearings that make up a bearing system simultaneously. Many air moving device suppliers base their calculations on a single bearing and fail to evaluate the statistical probability associated with the fact that there are two bearings in a motor. Although our methods of calculation result in lower life estimates it is more representative of a real world situation.

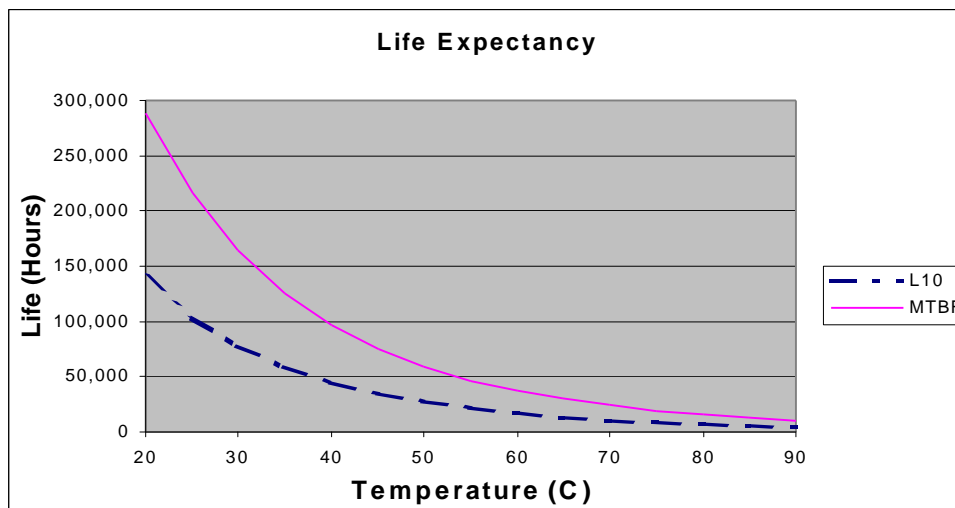

Mechanical Configuration

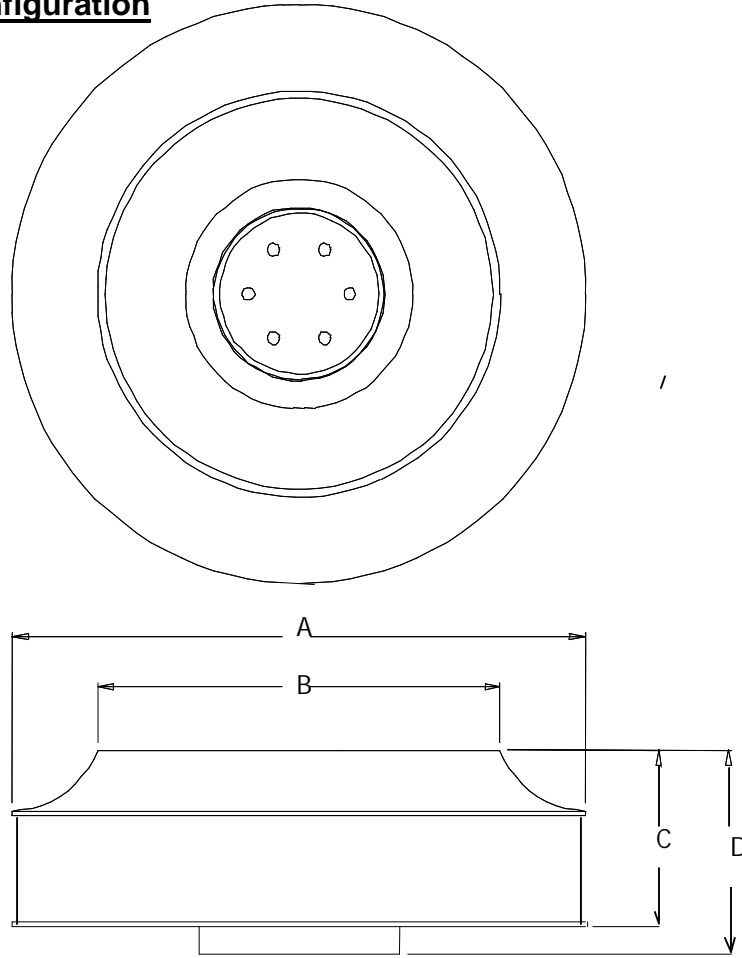

Motor Leads: Standard #20 Ga, 16 Inch Length

Red – Positive

Yellow - Control

Black – Return

Blue - Tach/Alarm

Mounting Holes: 4 Holes, M4 Thread, Equally Spaced @ 2.28" B.C.D.

Impeller Material	"A" in (mm)	"B" in (mm)	"C" in (mm)	"D" in (mm)
Metal	9.92 (252)	6.77 (172)	3.91 (99.3)	4.33 (110.0)

